

**st STARLINE**<sup>®</sup>  
forged steel ball valves

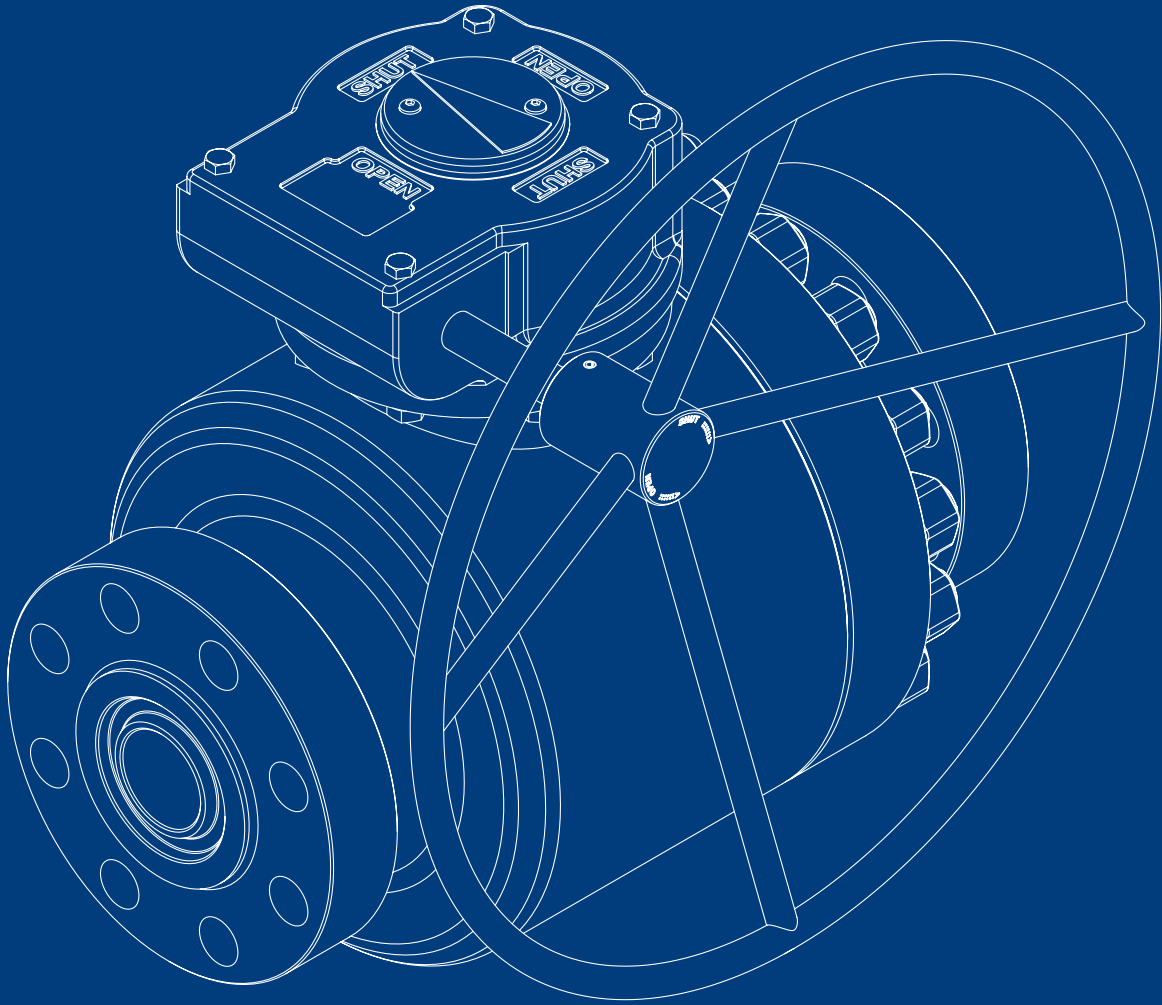

STARLINE

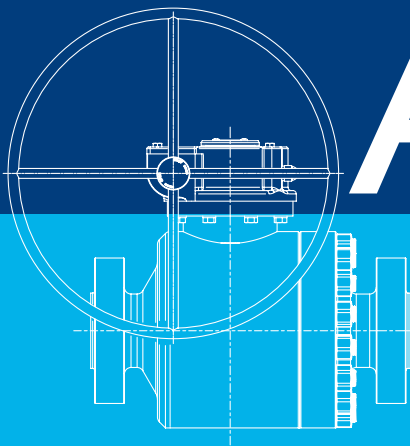

# API 6A

## BALL VALVES

**Starline** manufactures a complete line of ball valves in according to API 6A.

They are available in an extensive range of designs, materials, sizes and pressure classes and are in full conformance with API and NACE specifications.

Starline uses only high-quality forged materials inspected & tested to International Standards and utilizes advanced manufacturing technology with special emphasis on safety, quality, and long service life of products.

The forging material can ensure the best rigidity and strength.

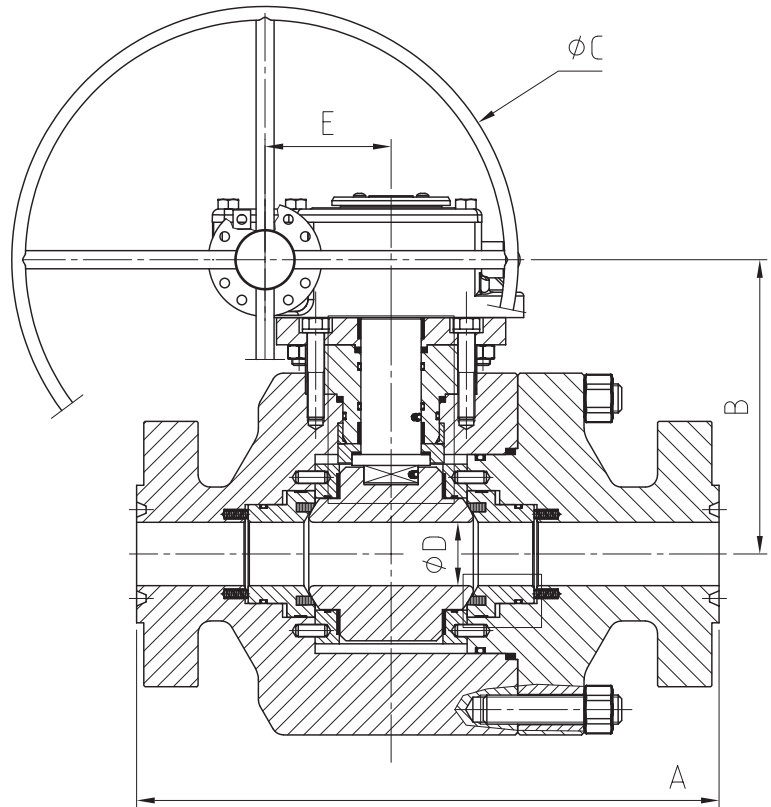

## MAIN FEATURES

- Standard seat design is single piston effect. Double piston effect sealing barrier available on request.
- Anti-Blow Out stem design.
- Antistatic device.
- Valve designs are available to meet Pressure Product Requirement levels PSL-1, PSL-2, PSL-3 / PSL-3G and PSL-4.
- Modular double block and bleed valves (two ball and a needle system) according to API 6A are available on request.

**FEA**

Starline uses the **FEA** for designing its **API 6A** ball valves.

Finite Element Analysis (FEA) is a very important step of the development phase and ensures the best possible performance requirements.

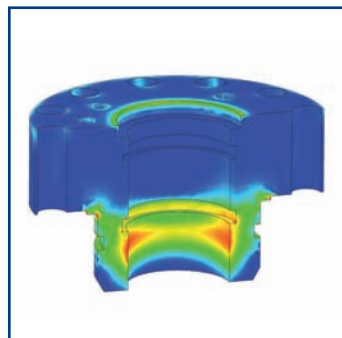
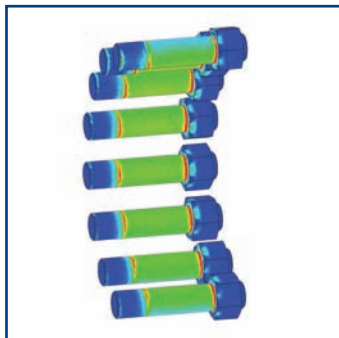
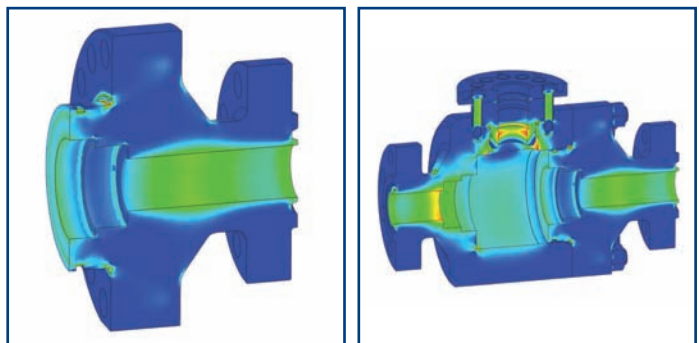

Valves operational problems, pressure/temperature related deformations and flow-related forces within a valve can be evaluated.

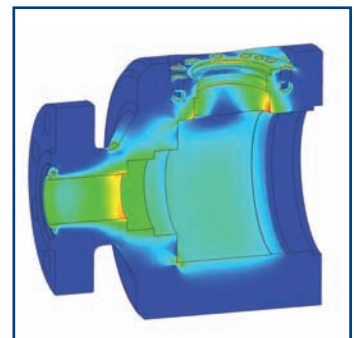

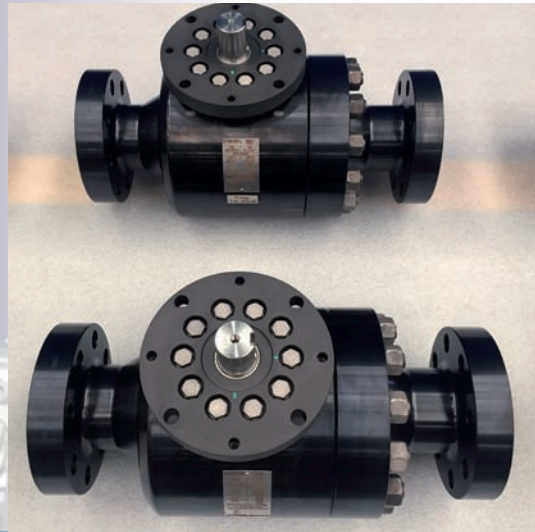

**Starline** performs in its facilities different non-destructive testing like ultrasonic, penetrant test, magnetic particles as defined by ASME B16.34.

Starline personnel performing NDT is trained and qualified to EN 473/ ASNT-SNT-TC-1A.

The API 6A designates 2 levels of testing under the categories PR 1, and PR 2 (PR meaning "Performance Requirement"), PR 2 requiring more testing than PR 1. Starline performs internally in its facilities both levels of performance testing.



Since its foundation on 1976 Starline has been focus only on production of Ball Valves in Forged Materials. After more than 40 Years the imprinting philosophy is still present and the base for the Company growth and success. Starting from the experience on the floating valves during the years, Starline has developed a wide and complete range of ball valves in different materials and executions introducing Trunnion Mounted design, Single and Double Block and Bleed, Metal to Metal,

Cryogenic and High temperature design. Today Starline with a production capacity of 250.000 valves/year, a complete size range and pressure ratings ½” to 36” – class 150- 2500lbs, API6A rate 3000-15000PSI in all the possible configurations and materials, is considered both by Customers and other Valve Manufacturers one of the Worldwide Market Leaders in Upstream Oil & Gas Applications which represent more than 70% of the final products destination.

## PHILOSOPHY

Starline's philosophy is based on the achievement of the standardization of the highest quality requirements in each single product. All materials used are mandatory produced in Western Europe and all forging companies are located in Italy.

A product **FULLY MADE IN ITALY**



## REFERENCES

- ADCO
- ADGAS
- ADMA-OPCO
- BP
- DSME
- ENI
- EXXON MOBIL
- GASCO
- GRT GAZ
- GAZPROM
- HYUNDAI (HHI)
- INPEX
- JGC CORPORATION
- KBR
- KNPC
- KOC
- NIOC
- NISOC
- NPCC
- PDO
- PETROBRAS
- PETROFAC
- PTSC
- PTTEP
- QATARGAS
- SAIPEM
- SAMSUNG (SHI)
- SHELL CHEVRON
- SNAMPROGETTI
- STATOIL
- TECHNIP
- TECNIMONT
- TOTAL E&P
- TOYO
- ZADCO



All the **Starline** API 6A ball valves are identified on proper name plate and on valve body as required by API 6A, MSS-SP 25, ASME B16.34. Nameplate indicates all information on rating, size, valve body and trim material, customer tags. Body marking includes material designations (as per ASTM) and heat code.

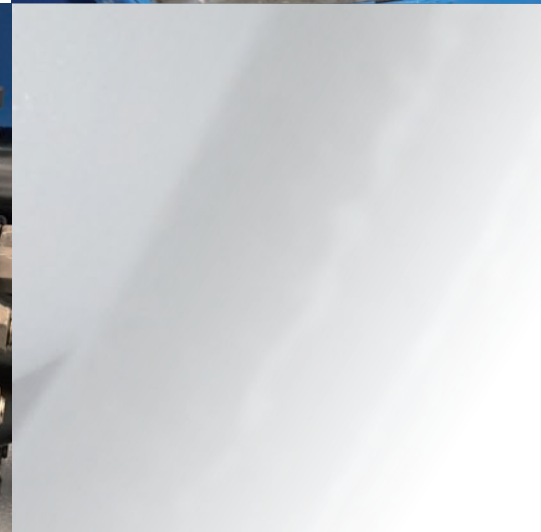

## STANDARDS AND CERTIFICATIONS

ISO 9001: 2008

PED 2014/68/EU MOD.H CAT.3

ATEX 2014/34/EU

SIL 3

CU-TR

ASME B16.5 – ASME B16.10

ASME B16.25 – ASME B16.34

ASME B16.11 – ASME B1.20.1

ASME VIII

API 6D

API 6DSS

API 6A ISO10423

FIRESAFE API607-API 6FA- ISO10497

BS 6364

NACE MR0175 – NACE MR0103

SHELL TAT

ISO 15848



Type in 'StarlineAR' and DOWNLOAD NOW

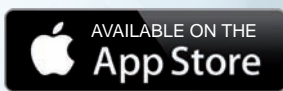



**Starline S.p.A. - Società Unipersonale**

Via dei Livelli di Sopra, 11 - 24060 Costa di Mezzate (BG) Italy  
tel. +39 035 958041 / +39 035 958102 - fax +39 035 958413  
[www.starline.it](http://www.starline.it) - [starline@starline.it](mailto:starline@starline.it)

**STARLINE BALL VALVES Ltd.**

Unit 6, Interlink Way South  
Bardon Hill, Coalville, Leicestershire, LE67 1PH  
UK  
Phone.: +44 (0) 1530 815818  
Fax.: +44 (0) 1530 815819  
[starline@acvalvealliance.com](mailto:starline@acvalvealliance.com)  
[www.acvalvealliance.com](http://www.acvalvealliance.com)

**STARLINE FRANCE S.a.r.l.**

7, Parc d'Activités de la Verdière  
13880 Velaux  
FRANCE  
Phone : +33 (0) 442878400  
Fax : +33 (0) 442878404  
[infos@star-line.fr](mailto:infos@star-line.fr)  
[www.star-line.fr](http://www.star-line.fr)

**STARLINE VALVES OY**

Koivuhaantie, 2-4 C  
01510 Vantaa  
FINLAND  
Phone: +358 (0) 98787711  
Fax : +358 (0) 98787221  
[starline@starline.fi](mailto:starline@starline.fi)  
[www.starline.fi](http://www.starline.fi)